

IZA500G-F5/GR-F5 Installation Guide

ALPR All-in-one AI Camera System



Table of Contents

- 1. Recommended Reading/Related Documents
- 2. Training and Support
 - 2.1. Training
 - 2.2. Support
- 3. Checklist
- 4. Prepare Components and Tools
 - 4.1. Package Contents
 - 4.2. Required Accessories
 - 4.3. Optional Accessories
 - 4.4. Tools
 - 4.5. Laptop Computer
- 5. Plan Your Site
 - 5.1. Horizontal Field of View (Capture Line)
 - 5.2. Angles and Distances
 - 5.3. Position of the Sun in Relation to the Camera
 - 5.4. Additional Installation Considerations
- 6. Prepare Cables
- 7. Install Camera System(s) and Other Components
- 8. Connect Components (Wiring)
 - 8.1. Typical Wiring Diagrams
- 9. Power Up and Set Up IP
 - 9.1. Connecting the Power
 - 9.2. Reserving IP Addresses in your Network
 - 9.3. Set Up IP

- 10. Configure LPR/OV Camera (Sensor) Settings
 - 10.1. Logging In to a Camera
 - 10.2. Live View (link at upper left)
 - 10.3. Admin (link at upper left)
 - 10.4. Logging Out of the Camera
 - 10.5. Changing a Camera's IP Address
 - 10.6. IZA500G LPR Camera (Sensor) Configuration
 - 10.6.1. IZA500G LPR Camera - Video & Audio > Stream Setup
 - 10.6.2. IZA500G LPR Camera - Video & Audio > Camera Setup
 - 10.6.3. IZA500G LPR Camera - System > Access Level
 - 10.7. IZA500G OV Camera (Sensor) Configuration
 - 10.7.1. IZA500G OV Camera - Video & Audio > Stream Setup
 - 10.7.2. IZA500G OV Camera - Video & Audio > Camera Setup
 - 10.7.3. IZA500G OV Camera - System > Access Level
 - 10.8. IZA500GR LPR Camera (Sensor) Configuration
 - 10.8.1. IZA500GR LPR Camera - Video & Device > Stream Setup (Video Streams)
 - 10.8.2. IZA500GR LPR Camera - Video & Audio > Camera Setup
 - 10.8.3. IZA500GR LPR Camera - System > Access Level
 - 10.9. IZA500GR OV Camera (Sensor) Configuration
 - 10.9.1. IZA500GR OV Camera - Video & Audio > Stream Setup (Video Streams)
 - 10.9.2. IZA500GR OV Camera - Video & Audio > Camera Setup
 - 10.9.3. IZA500GR OV Camera - System > Access Level
- 11. Aim and Calibrate
 - 11.1. Preparing a Vehicle/License Plate
 - 11.2. Determining the IP Address of the RoadView Computer with IZ Discovery
 - 11.3. Using RoadView
 - 11.3.1. Logging In
 - 11.3.2. Logging Out
 - 11.4. Calibrating the Cameras Using RoadView
- 12. Verify System Operation
- 13. Troubleshooting and Maintenance
 - 13.1. Troubleshooting
 - 13.2. Checking Mounting Screws
 - 13.3. Cleaning the ALPR Camera System
- 14. Notices
 - 14.1. Inex Technologies End User Agreement
 - 14.2. Safety Precautions
 - 14.3. Regulatory Notices
 - 14.4. Documentation Notices
- 15. Document Change History

1. Recommended Reading/Related Documents

Table 1. Related Documents

Doc. No.	Title
IZA500G-F5-GR-F5-MAN-002b	IZA500G-F5/GR-F5 Installation Guide
IZA500G-F5-GR-F5-TECH-001	IZA500G-F5/GR-F5 Quick Start Guide
IZA500G-REV-xx-TDSHEET	IZA500G Technical Data Sheet
IZA500GR-REV-xx-TDSHEET	IZA500GR Technical Data Sheet
MOUNT-MAP-PRSNT-011	Product-to-Mount Mapping
Mounts	Mounting Hardware documentation
IZ Discovery Utility	IZ Discovery Utility software components
IZDISCOVERY-MAN-001	IZ Discovery User Guide
RoadView Documentation	RoadView Documentation
EULA-400-DOC-001	Software End User License Agreement (includes list of open source software)
IZPWRDIN-REV-x-TDSHEET	IZPWR DIN Rail Mount Power Supplies Technical Data Sheet
IZIO-6060-MAN-001	IZIO Digital I/O Controller Installation and User Guide
IZxPOE-DIN-REV-xxx-TDSHEET	IZxPOE DIN Rail Mount Gigabit PoE++ Injector Technical Data Sheet
LOOP-DTCR-L-MAN-001	LOOP-DTCR-L Loop Detector Installation and User Guide
NDAANB-COC-001	NDAANB Section 889 Certification of Compliance

2. Training and Support

2.1. Training

This document does not take the place of training by Inex Technologies' certified specialists. Contact Inex Technologies to schedule training.

2.2. Support

If you have any questions, please contact our support team via our [Inex Technologies Website](#).

3. Checklist

- ✓ Prepare components and tools
- ✓ Plan your site
- ✓ Prepare cables
- ✓ Install Camera System(s) and other components
- ✓ Connect components (wiring)
- ✓ Power up and set up IP
- ✓ Configure LPR/OV camera settings
- ✓ Aim and calibrate
- ✓ Verify system operation

4. Prepare Components and Tools

4.1. Package Contents

Carefully unpack the contents of the ALPR Camera System package. (For a detailed view of the cables, see Figure 8.)

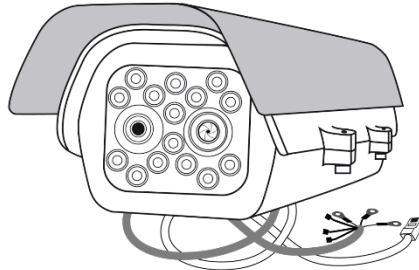

ALPR Camera System

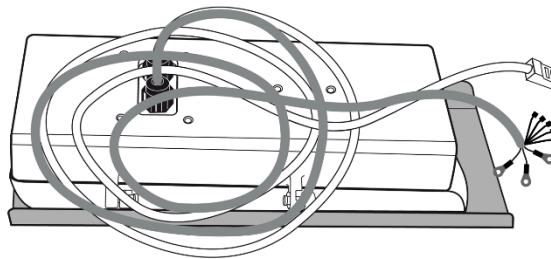

Cables (underside of Camera System)

Figure 1. Package Contents

The package includes:

- IZA500G-F5/GR-F5 ALPR All-in-one AI Camera System

If any parts are missing or damaged, please contact Inex Technologies.

4.2. Required Accessories

The following accessories can be supplied by Inex, For documentation and part numbers, see Section 1.

Table 2. Required Accessories

Item	Notes
24 VDC power supply (if the IZA500GR PoE++ option is not used; voltage-adjustable)	INEX/TECH model power supply.
IZxPOE Gigabit PoE++ Injector	Used for IZA500GR P24 models when using the PoE++ power input with a non-PoE++ network switch; alternatively, connect directly to the Camera System from a standard PoE++ network switch
Mounting Hardware (pan-tilt-roll bracket)	Typically on wall or pole; see the Mounting Hardware documentation for details (see Section 1)

4.3. Optional Accessories

For documentation and part numbers, see Section 1.

- IZIO Digital I/O Controller
- Loop Detector

4.4. Tools

- An Allen wrench used to attach the mounting adapter plate to the housing (if applicable); size 3/16" (4.76 mm)
- Network (LAN) cabling (typically CAT 5e/6 cable) with metal-body RJ45 connectors. The total length of the cable should not exceed 328 feet (100 meters).
- Tools for building LAN cables (wire stripper, crimp tool, etc.) and RJ45 connectors with metal bodies.

! IMPORTANT

For installations that require network cabling: typically use CAT 5e/6 cable. The total length of the cable should not exceed 328 feet (100 meters).

All network cable extensions and repeaters must be shielded.

4.5. Laptop Computer

- You will need to provide a laptop computer to use for configuration. If you will be using the laptop outdoors, the screen must be able to be seen in strong sunlight. Required software:
 - Windows 10 or above - with .NET 4.5 enabled in "Windows Features"
 - Chrome or Microsoft Edge browser

5. Plan Your Site

5.1. Horizontal Field of View (Capture Line)

Your camera's Field of View (FOV) is the area that the camera can "see". You can think of this area as an imaginary rectangle rising from the lane upwards. The width of this area is called the horizontal FOV or "capture line".

See your camera's User Guide for the horizontal and vertical FOV specifications.

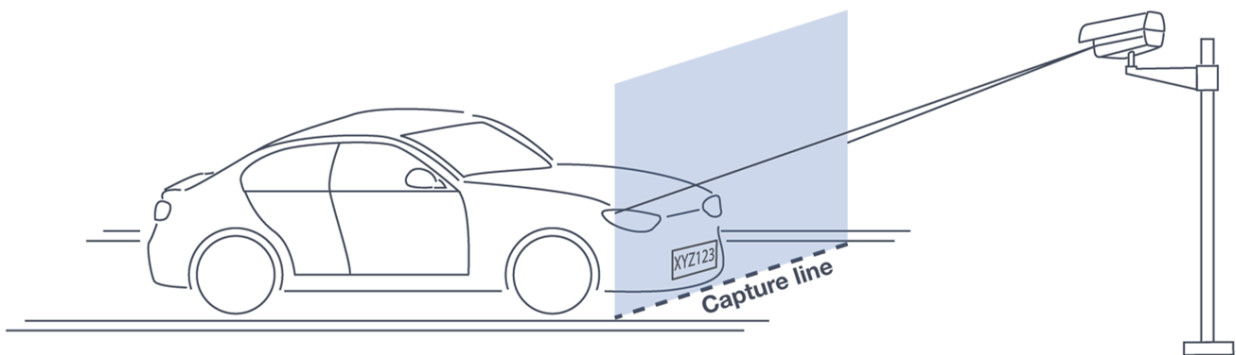

Figure 2. Field of View (Capture Line)

Select your camera's position so that license plates are always within the capture line and parallel to it, with the camera facing as straight at the plates as possible - as shown in the following diagrams:

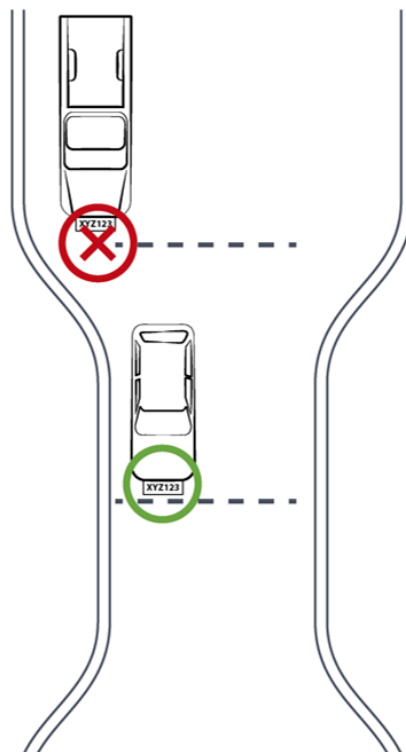

Figure 3. Plates Within Capture Line

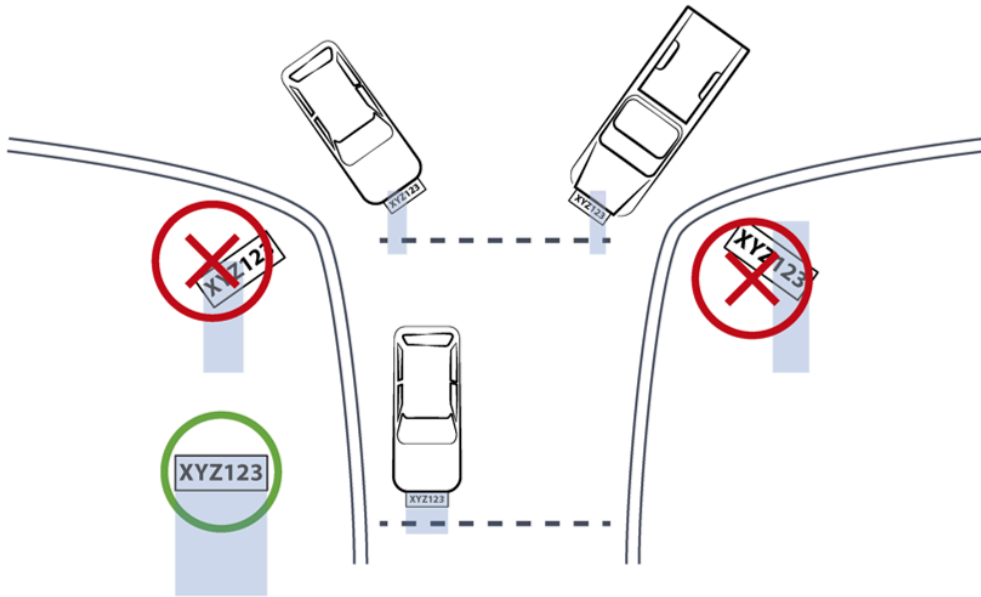

Figure 4. Plates Parallel to Capture Line - Away from Road Curves

5.2. Angles and Distances

! IMPORTANT

See your camera's data sheet for capture distance specifications.

Installations that position the camera at significant angles in relation to the plates will reduce the line-of-sight distances specified.

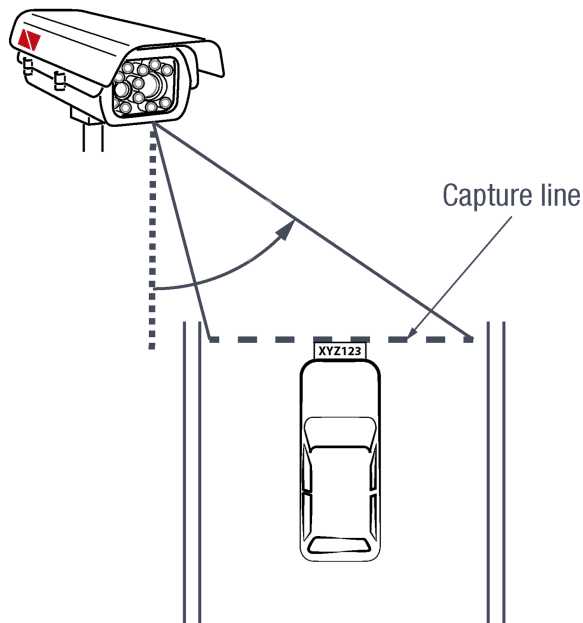

Figure 5. Horizontal Camera Angle (Pan Angle)

i NOTE

See your camera's data sheet for capture distance specifications.

If you must capture plates on a curve, place the camera on the side of the road that minimizes the horizontal angle.

At larger angles, the reflectivity of the plates is reduced, resulting in images with less contrast.

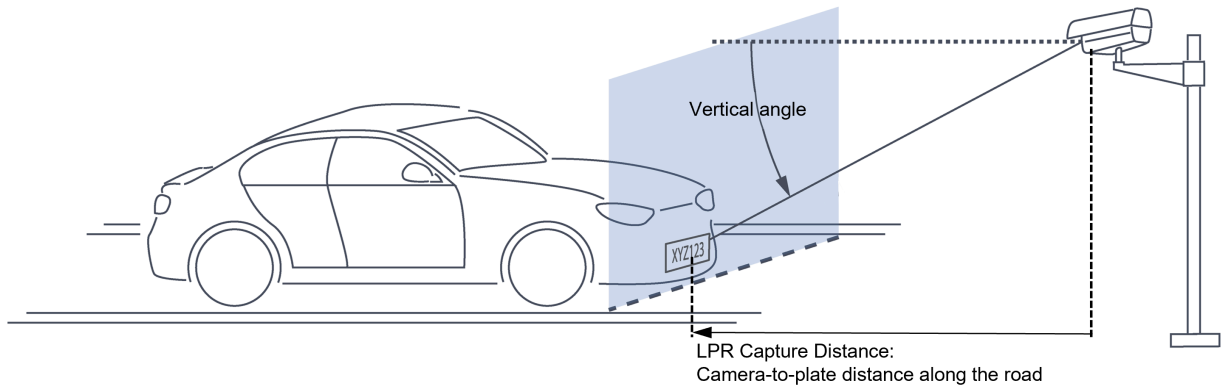

Figure 6. Vertical Camera Angle (Tilt Angle) and LPR Capture Distance

i NOTE

See your camera's data sheet for capture distance specifications.

The distance from the camera to the capture line must be within the viewing range of the LPR camera.

Adjust the vertical angle so that the camera can read plates at all of their expected heights from the road.

Larger angles and/or greater mounting heights may be required in order to recognize plates on vehicles close to each other (such as in slow/congested traffic).

At larger angles, the reflectivity of the plates is reduced, resulting in images with less contrast.

5.3. Position of the Sun in Relation to the Camera

The camera should not be positioned so that the rays of the sun behind the camera shine along the camera-to-plate axis. Reflective plates will cause severe glare to be reflected back to the camera, obscuring the image of the plate's characters.

Avoid/mitigate by:

- Not installing the camera in an east/west direction
- Installing the camera near a building that shields it from the sun's rays
- Installing the camera on a short pole
- Using a double-camera installation (2 different angles or front/rear)

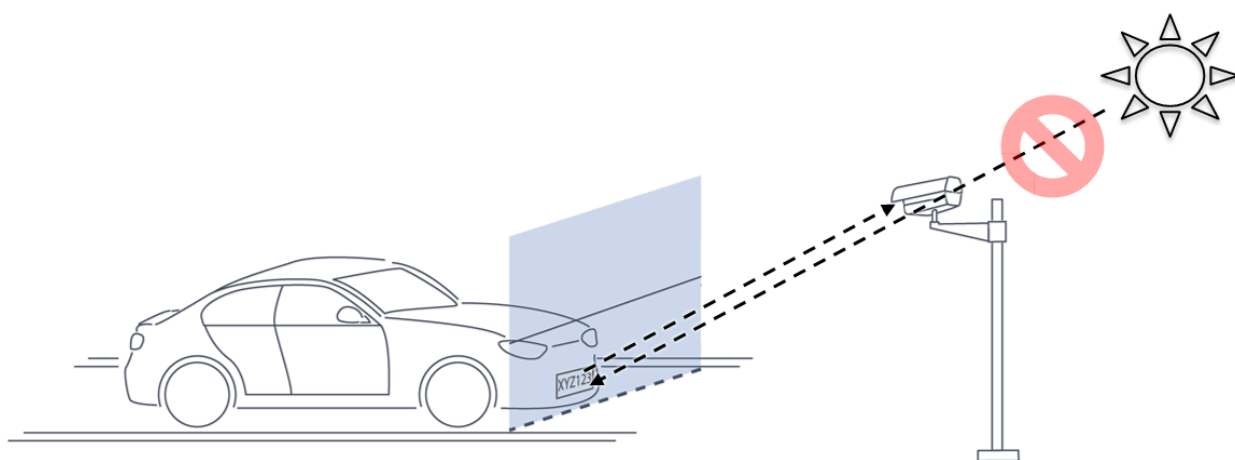

Figure 7. Sun Behind Camera (on Same Axis as Line-of-Sight from Camera to Plate)

5.4. Additional Installation Considerations

Table 3. Additional Installation Considerations

Item	Considerations
Surge Protection	<ul style="list-style-type: none"> • On power, network and data cables
Correct, Stable and Sufficient Power	<ul style="list-style-type: none"> • Power undervoltage, overvoltage and/or incorrect polarity will damage the unit and will void the warranty. • Stable power at the correct level must be supplied to each Camera System, even when under a heavy processing load.
Cable Extensions IMPORTANT <u>All network cable extensions and repeaters must be shielded.</u>	<ul style="list-style-type: none"> • Power - Use a cable gauge sufficient to deliver the required voltage at the Camera System • LAN - Use only CAT 5e/6 cable for any extensions added to the LAN cable. The total length of the cable (without a switch) should not exceed 328 feet (100 meters).
Front/Rear Capture - or Both	<ul style="list-style-type: none"> • Country requirements • Vehicle types • Protruding parts that obscure plates (such as rear hooks) • Recessed plates • Desired pre- or post-capture in relation to ticket issue (for parking)
Objects with character-like appearances (interpreted as characters on a plate, resulting in false reads)	Avoid having these items in the Field of View: <ul style="list-style-type: none"> • Fences with patterns • Barriers • Signs
Obstructions (blocking FOV)	<ul style="list-style-type: none"> • Entry gates • Trees and bushes (even before fully grown) • Bright light (sun/artificial) shining directly into Camera System's front window • Reflective surfaces too close to camera lens • Weather - snow, heavy rain, dust storms • Dirt on front window (see Section 13)
Mounting	<ul style="list-style-type: none"> • Typically on wall/pole • Additional construction if needed

6. Prepare Cables

! IMPORTANT

The trigger wires have the same functions and colors as shown here, but the label on the cable may be worded differently.

When adding extensions to the built-in cables, be sure that there are stable/correct signal and power levels delivered to all components.

For installations that require network cabling: typically use CAT 5e/6 cable. The total length of the cable should not exceed 328 feet (100 meters).

All network cable extensions and repeaters must be shielded.

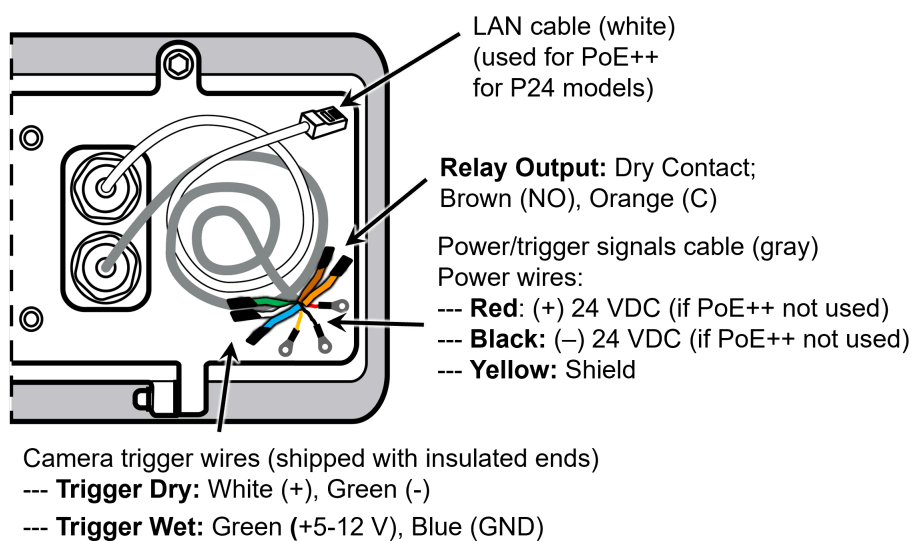

Figure 8. Cable Details

7. Install Camera System(s) and Other Components

! IMPORTANT

Before mounting components, see Section 8 to ensure that your site plan accommodates how the components will be wired together.

After mounting, remove the protective film from the front window of the Camera System.

1. Secure the Camera System(s) to the appropriate mounting hardware (see the Mounting Hardware documentation - see Section 1).
2. Mount other components (such as junction boxes) in appropriate locations.

8. Connect Components (Wiring)

8.1. Typical Wiring Diagrams

See Table 4 for a legend/bill of materials.

! WARNING

Turn off/disconnect the external (AC) power supply before connecting cables.

If you are using an Inex power supply, see its User Guide (see Section 1) for important information.

i NOTE

If you are using a DIN rail-mount power supply, you will need to cut off the rings at the ends of the Camera System's power connections, and attach pins in their place.

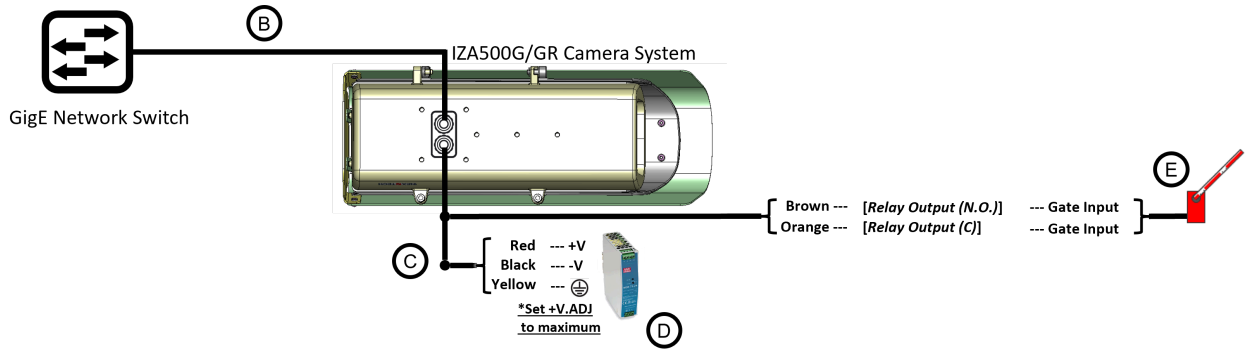

Figure 9. Typical Camera System Wiring Diagram

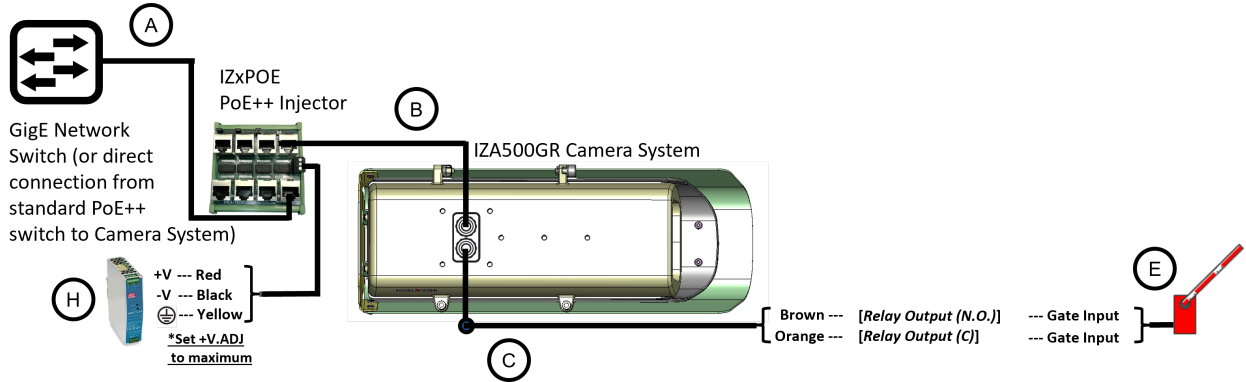

Figure 10. Typical Camera System Wiring Diagram with PoE++ (IZA500GR P24 Models)

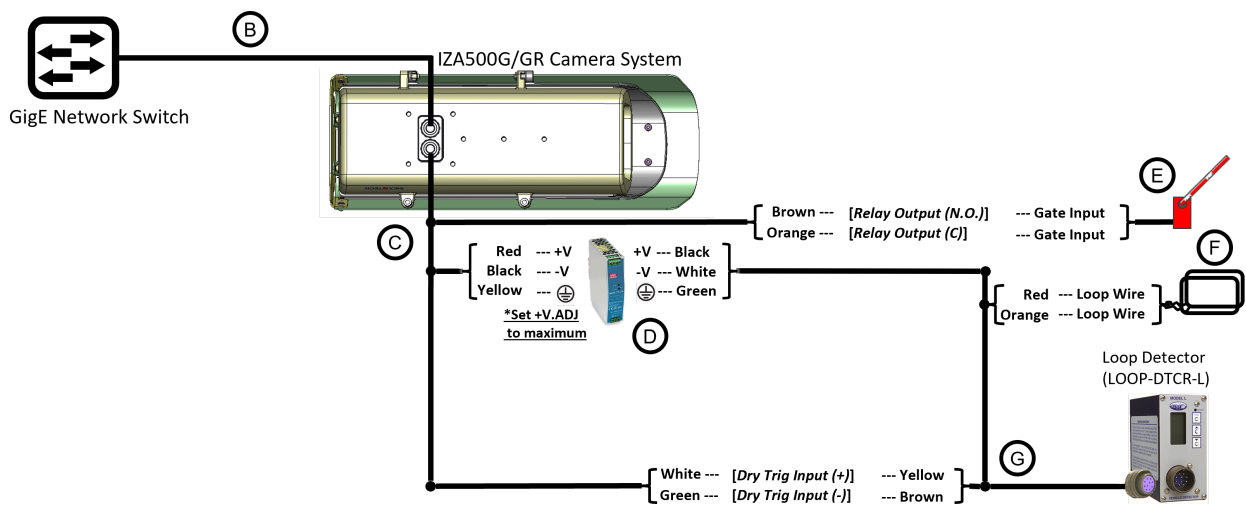

Figure 11. Typical Camera System with Inductive Loop Wiring Diagram

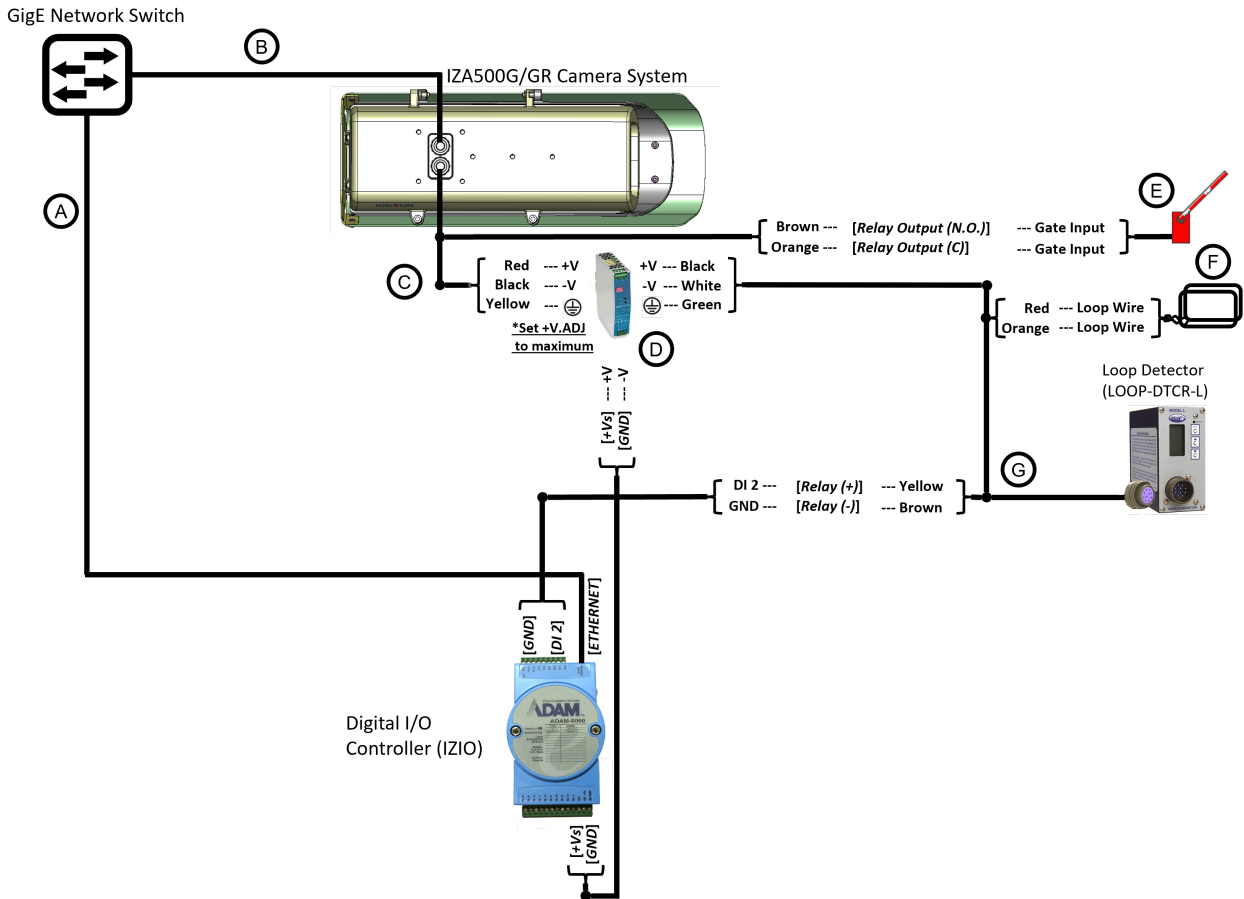

Figure 12. Typical Camera System with I/O Module Wiring Diagram

Table 4. Wiring Diagram Legend/Bill of Materials

Item	Description	Ordering Information
A	LAN Patch Cable - CAT6, max. length 3.3 ft (1 m) for connection to IZxPOE; 382 ft (100 m) for connection to IZIO	Supplied by integrator
B	LAN Cable - CAT6, shielded, 4 pairs, 22 AWG, max. length 328 ft (100 m), OD 5.5-7.9 mm	Supplied by integrator; 6.6 ft (2 m) included with camera
C	PAS (Power and Signals) Cable - 22 AWG, OD 3.0-7.3 mm	Supplied by integrator; 6.6 ft (2 m) cable included with camera
D	Power Supply for Cameras 24 VDC if PoE++ is not used	For 1 camera, use a 50/75 W supply (IZPWR75) For 2 cameras, use a 100/120 W supply (IZPWR120) For 4 cameras, use a 240 W supply (IZPWR240)
E	Gate	Supplied by integrator
F	Inductive Loop	Supplied by integrator
G	Loop Detector Wiring Harness	Included with Loop Detector

Item	Description	Ordering Information
H	Power Supply for IZxPOE PoE++ Injector Requires 48 VDC	For 1 camera, use a 75 W supply (IZPWR75-48) For 2 cameras, use a 120 W supply (IZPWR120-48) For 4 cameras, use a 240 W supply (IZPWR240-48)

- For device configuration instructions, see the LOOP-DTCR-L and IZIO guides.
- IZA500GR: Works with standard PoE++ switches, or an Inex IZxPOE PoE++ injector

9. Power Up and Set Up IP

9.1. Connecting the Power

WARNING

If any power cables were lengthened, ensure that all components receive exactly their rated voltage.

Power undervoltage, overvoltage and/or incorrect polarity will damage the unit and will void the warranty.

Stable power at the correct level must be supplied to each Camera System, even when under a heavy processing load.

Connect a plug to the Live (+V), Neutral (-V) and Ground (Shield) terminals of the power supply (see Section 8.1).

Plug the power supply into the AC electricity. If required, switch the power supply unit ON.

9.2. Reserving IP Addresses in your Network

The Inex cameras have been pre-configured with default IP addresses. You will probably need to change these addresses to conform to the requirements of your network. Be sure that you have IP addresses reserved for all components of your ALPR system (RoadView computer and cameras).

9.3. Set Up IP

The IZ Discovery utility discovers all active devices connected to the network, and displays a list of their network parameters. These devices can include cameras and computers.

See the IZ Discovery User Guide (see Section 1) for instructions on how to change a Camera System's IP address.

10. Configure LPR/OV Camera (Sensor) Settings

10.1. Logging In to a Camera

1. To view the camera's home page (see Figure 13):

Open a browser. Enter the IP address of the camera into the address field.

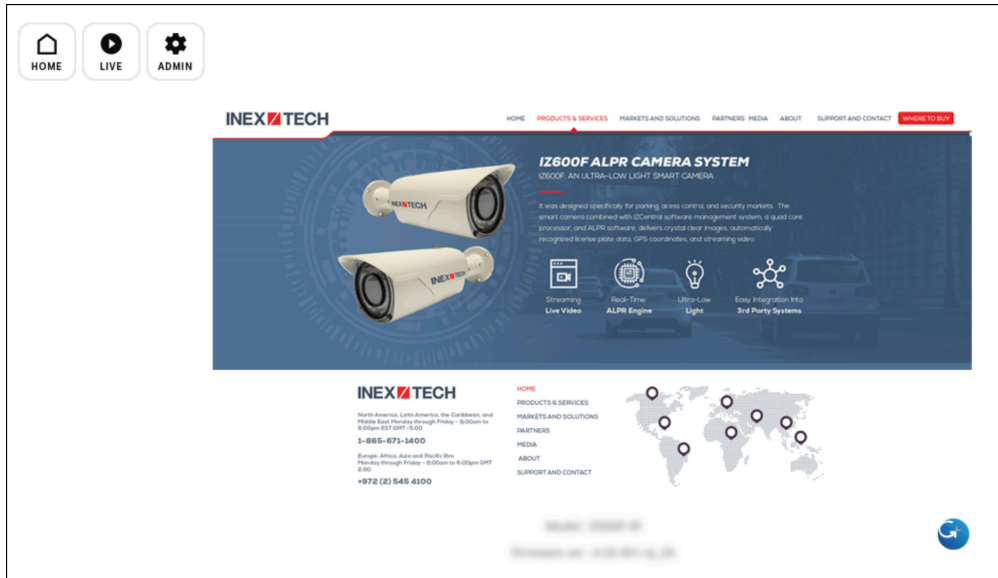

Figure 13. Camera's Home Page

2. Select the function you need from the links/buttons at the upper part of the screen:

- Click the Live link/button to see what the camera is currently viewing. Use the default user/password: root/IZpass12.

i NOTE

When using Live View for the first time, you may be prompted to download and install an ActiveX control (Smart Viewer).

If you do not have an internet connection to the network on which the camera is installed, wait 30 seconds, and you will be instructed on how to install the ActiveX control locally via the camera's firmware.

The stream of the Live View can also be accessed using an RTSP URL with this format :

`rtsp://[username:password]@<Camera IP address>/cam0_0`

where cam0_0 is a camera-specific parameter (which in this case enables you to access the primary stream)

To see the stream, use a video player such as the VLC player, located at:

[VLC](#)

- If you need to change the camera's IP address or other configuration parameters, click the Admin link/button. When prompted for a login, use the Administrator username/password credentials of root, IZpass12.

! IMPORTANT

The Administrator user name (root) cannot be changed, and the Administrator password is encrypted. Therefore, if someone changes the Administrator password, there is no way to find out the password if it gets lost.

10.2. Live View (link at upper left)

- The focus will typically be set automatically; in some cameras, it can be fine-adjusted manually with buttons
- Some cameras can use the Zoom in/out buttons

10.3. Admin (link at upper left)

- Enter username and password (root/IZpass12)
- Use the menu at the left to select the parameter category/sub-category/group.

! IMPORTANT

After changing settings, remember to click the Apply button at the bottom of each parameter section.

10.4. Logging Out of the Camera

Close all windows, and the browser window.

10.5. Changing a Camera's IP Address

i NOTE

It is highly recommended to use a fixed IP address (not DHCP). A fixed IP address enables you to access the camera using the same URL every time, even after unexpected power outages.

You can also use IZ Discovery to change the camera's IP address.

1. In the Network group, click on IP Address:

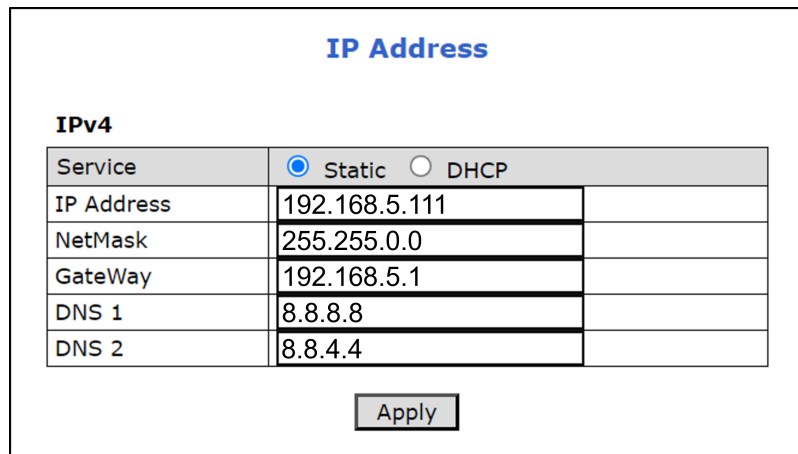

IPv4	
Service	<input checked="" type="radio"/> Static <input type="radio"/> DHCP
IP Address	192.168.5.111
NetMask	255.255.0.0
GateWay	192.168.5.1
DNS 1	8.8.8.8
DNS 2	8.8.4.4

Apply

Figure 14. Changing the Camera's IP Address

2. To change the IP address to a fixed one:

i NOTE

The IP address must be unique within the entire ALPR system, and must be within the limits of standard IPv4 address numbering.

- Click the Static radio button.
- Enter the network address parameters. **All cameras must be on the same subnet as both the computer you will use to communicate with and configure the camera, and the Inex RoadView computer.**

! IMPORTANT

It is highly recommended to record the camera's IP address and port number in a safe place. You will need them if the camera's parameters are reset back to their defaults, and for configuring Inex recognition software.

3. Click Apply.

! IMPORTANT

After selecting Apply, you will be requested to close your web browser so the updates can take effect.

This will take 20 seconds or more, to allow the camera time to reboot.

- If you click the browser's Back button, all values will be discarded.

- If you click the browser's Refresh button, the application will load the previous values.

4. In the IZ Discovery utility, click the "Clear List" button, and verify that the camera can be recognized with the new IP address.

10.6. IZA500G LPR Camera (Sensor) Configuration

The camera(s) are usually pre-configured; this section displays typical settings for reference.

! IMPORTANT

Settings shown are for a typical site; they may be different depending on you site's requirements and camera firmware versions.

Settings may vary based on your site's lighting conditions.

After changing settings, remember to click the Apply button at the bottom of each parameter section.

10.6.1. IZA500G LPR Camera - Video & Audio > Stream Setup

Stream Setup

Max Frame Rate	<input checked="" type="radio"/> 30 fps <input type="radio"/> 25 fps
Video with Flexible Extra System data	<input checked="" type="checkbox"/> Enable
Video with user defined message	<input type="checkbox"/> Enable
Video with PPP status	<input type="checkbox"/> Enable
Video with camera name	<input type="checkbox"/> Enable
Video with server name	<input type="checkbox"/> Enable
Video with IP address	<input type="checkbox"/> Enable
Time Stamp	Off <input type="button" value="v"/>
TV Out	<input checked="" type="radio"/> Enable <input type="radio"/> Disable
Audio Codec	G.711 μ -LAW <input type="button" value="v"/>
<input type="button" value="Apply"/>	

Primary Secondary Tertiary	
Camera Name	Primary Stream
Frame Rate	15 fps <input type="button" value="v"/>
Image Size	1920 x 1080 <input type="button" value="v"/>
Encoding Standard	M-JPEG <input type="button" value="v"/>
Image Quality	Normal <input type="button" value="v"/>
Audio	<input type="radio"/> Enable <input checked="" type="radio"/> Disable
<input type="button" value="Apply"/>	

Max. Video Encoding	2M x 30 fps <input type="button" value="v"/>
<input type="button" value="Apply"/>	

Figure 15. IZA500G LPR Camera - Video & Audio > Stream Setup

10.6.2. IZA500G LPR Camera - Video & Audio > Camera Setup

i NOTE

Click the Default(Day) link, and set the Shutter Time Max parameter according to the camera-to-plate distance (see next Figure):

Distance	Shutter Time Max
35 ft (11 m)	1/500
20 ft (6.0 m)	1/1000
15 ft (4.6 m)	1/2000
10 ft (3.0 m)	1/4000

i NOTE

Change the Exposure parameter "Environment" to Outdoor or Indoor, depending on your site's requirements.

Default(Day) Night Mode DI Mode Motion Mode				
Event Control Mode				
Change Mode to	Day	Night	DI	Motion
	<input type="checkbox"/>	<input type="checkbox"/>	<input type="checkbox"/>	<input type="checkbox"/>
Exposure				
Environment	<input type="radio"/> Indoor <input checked="" type="radio"/> Outdoor			
AE Metering Mode	Center ▾			
Shutter Control	<input checked="" type="radio"/> Manual <input type="radio"/> Auto			
Shutter Time Min	1 / 4000	(30 ~ 32000)		
Shutter Time Max	1 / 4000	(30 ~ 32000)		
Max AGC gain	1	(Default:36, 0 ~ 72)		
Sense Up Level	Off ▾			
Back Light Compensation	<input type="radio"/> Enable <input checked="" type="radio"/> Disable			
Auto Exposure Weight	100	% (Default:100, 25 ~ 400)		
D-WDR Enable	<input type="radio"/> Enable <input checked="" type="radio"/> Disable			
D-WDR	0	(Default:0, 0 ~ 128)		
Image Filter				
Brightness	0	(Default:0, -255 ~ 255)		
Contrast	85	(Default:64, 0 ~ 128)		
Hue	2	(Default:2, -15 ~ 15)		
Saturation	80	(Default:80, 0 ~ 255)		
Sharpness	7	(Default:6, 0 ~ 11)		
White Balance & Noise Filter				
White Balance	Auto ▾			
3DNR	3	(0 ~ 11)		
Day/Night & IR-LED Illumination				
Day & Night Control	Black & White ▾			
Day to Night Dwelling Time	3	(0 ~ 6)		
Night to Day Dwelling Time	3	(0 ~ 6)		
Day to night threshold	2000	(1 ~ 4096)		
Night to day threshold	3500	(1 ~ 4096)		
Image Direction				
Vertical Flip	<input type="radio"/> Enable <input checked="" type="radio"/> Disable			
Horizontal Flip	<input type="radio"/> Enable <input checked="" type="radio"/> Disable			
Corridor Mode	<input type="radio"/> Enable <input checked="" type="radio"/> Disable			
Color Mode : Default		Color Mode : Standard		
Color Mode : Vivid		Copy Default to All		
Apply				

Figure 16. IZA500G LPR Camera - Video & Audio > Camera Setup

10.6.3. IZA500G LPR Camera - System > Access Level

Access Level

Access Permission

<input checked="" type="radio"/> Full Access (View and control camera & audio without permission)
<input type="radio"/> Limited Access (In accordance with an user's permission)
<input type="button" value="Apply"/>

Authentication

<input checked="" type="radio"/> Unencrypted only <input type="radio"/> Encrypted only <input type="radio"/> Encrypted & Unencrypted
<input type="button" value="Apply"/>

Notice : In order to apply the settings to the 'Access Control Configuration', reconnection is required after closing the browser.

Figure 17. IZA500G LPR Camera - System > Access Level

10.7. IZA500G OV Camera (Sensor) Configuration

The camera(s) are usually pre-configured; this section displays typical settings for reference.

! IMPORTANT

Settings shown are for a typical site; they may be different depending on you site's requirements and camera firmware versions.

Settings may vary based on your site's lighting conditions.

After changing settings, remember to click the Apply button at the bottom of each parameter section.

10.7.1. IZA500G OV Camera - Video & Audio > Stream Setup

Stream Setup

Max Frame Rate	<input checked="" type="radio"/> 30 fps <input type="radio"/> 25 fps
Video with Flexible Extra System data	<input checked="" type="checkbox"/> Enable
Video with user defined message	<input type="checkbox"/> Enable
Video with PPP status	<input type="checkbox"/> Enable
Video with camera name	<input type="checkbox"/> Enable
Video with server name	<input type="checkbox"/> Enable
Video with IP address	<input type="checkbox"/> Enable
Time Stamp	Off <input type="button" value="v"/>
TV Out	<input checked="" type="radio"/> Enable <input type="radio"/> Disable
Audio Codec	G.711 μ -LAW <input type="button" value="v"/>
<input type="button" value="Apply"/>	

Primary Secondary Tertiary	
Camera Name	Primary Stream
Frame Rate	15 fps <input type="button" value="v"/>
Image Size	1920 x 1080 <input type="button" value="v"/>
Encoding Standard	M-JPEG <input type="button" value="v"/>
Image Quality	Normal <input type="button" value="v"/>
Audio	<input type="radio"/> Enable <input checked="" type="radio"/> Disable
<input type="button" value="Apply"/>	

Max. Video Encoding	2M x 30 fps <input type="button" value="v"/>
<input type="button" value="Apply"/>	

Figure 18. IZA500G OV Camera - Video & Audio > Stream Setup

10.7.2. IZA500G OV Camera - Video & Audio > Camera Setup

i NOTE

Click the Default(Day) link, and set the Shutter Time Max parameter according to the camera-to-plate distance (see next Figure):

Distance	Shutter Time Max
35 ft (11 m)	1/500
20 ft (6.0 m)	1/1000
15 ft (4.6 m)	1/2000
10 ft (3.0 m)	1/4000

i NOTE

Change the Exposure parameter "Environment" to Outdoor or Indoor, depending on your site's requirements.

Default(Day) Night Mode DI Mode Motion Mode				
Event Control Mode				
Change Mode to	Day	Night	DI	Motion
	<input type="checkbox"/>	<input type="checkbox"/>	<input type="checkbox"/>	<input type="checkbox"/>
Exposure				
Environment	<input type="radio"/> Indoor <input checked="" type="radio"/> Outdoor			
AE Metering Mode	Center ▾			
Shutter Control	<input checked="" type="radio"/> Manual <input type="radio"/> Auto			
Shutter Time Min	1 / 32000	(30 ~ 32000)		
Shutter Time Max	1 / 3000	(30 ~ 32000)		
Max AGC gain	1	(Default:36, 0 ~ 72)		
Sense Up Level	Off ▾			
Back Light Compensation	<input type="radio"/> Enable <input checked="" type="radio"/> Disable			
Auto Exposure Weight	120	% (Default:100, 25 ~ 400)		
D-WDR Enable	<input type="radio"/> Enable <input checked="" type="radio"/> Disable			
D-WDR	0	(Default:0, 0 ~ 128)		
Image Filter				
Brightness	0	(Default:0, -255 ~ 255)		
Contrast	90	(Default:64, 0 ~ 128)		
Hue	2	(Default:2, -15 ~ 15)		
Saturation	80	(Default:80, 0 ~ 255)		
Sharpness	7	(Default:6, 0 ~ 11)		
White Balance & Noise Filter				
White Balance	Auto ▾			
3DNR	3	(0 ~ 11)		
Day/Night & IR-LED Illumination				
Day & Night Control	Color ▾			
Day to Night Dwelling Time	3	(0 ~ 6)		
Night to Day Dwelling Time	3	(0 ~ 6)		
Day to night threshold	2000	(1 ~ 4096)		
Night to day threshold	3500	(1 ~ 4096)		
Image Direction				
Vertical Flip	<input type="radio"/> Enable <input checked="" type="radio"/> Disable			
Horizontal Flip	<input type="radio"/> Enable <input checked="" type="radio"/> Disable			
Corridor Mode	<input type="radio"/> Enable <input checked="" type="radio"/> Disable			
Color Mode : Default		Color Mode : Standard		
Color Mode : Vivid		Copy Default to All		
Apply				

Figure 19. IZA500G OV Camera - Video & Audio > Camera Setup

10.7.3. IZA500G OV Camera - System > Access Level

Access Level

Access Permission

<input checked="" type="radio"/> Full Access (View and control camera & audio without permission)
<input type="radio"/> Limited Access (In accordance with an user's permission)
<input type="button" value="Apply"/>

Authentication

<input checked="" type="radio"/> Unencrypted only <input type="radio"/> Encrypted only <input type="radio"/> Encrypted & Unencrypted
<input type="button" value="Apply"/>

Notice : In order to apply the settings to the 'Access Control Configuration', reconnection is required after closing the browser.

Figure 20. IZA500G OV Camera - System > Access Level

10.8. IZA500GR LPR Camera (Sensor) Configuration

The camera(s) are usually pre-configured; this section displays typical settings for reference.

! IMPORTANT

Settings shown are for a typical site; they may be different depending on you site's requirements and camera firmware versions.

After changing settings, remember to click the Apply button at the bottom of each parameter section.

10.8.1. IZA500GR LPR Camera - Video & Device > Stream Setup (Video Streams)

Stream Setup

Max Frame Rate	<input checked="" type="radio"/> 30 fps <input type="radio"/> 25 fps
Video with Flexible Extra System data	<input type="checkbox"/> Enable
Video with user defined message	<input type="checkbox"/> Enable
Video with PPP status	<input type="checkbox"/> Enable
Video with camera name	<input type="checkbox"/> Enable
Video with server name	<input type="checkbox"/> Enable
Video with IP address	<input type="checkbox"/> Enable
Time Stamp	Off <input type="button" value="v"/>
TV Out	<input checked="" type="radio"/> Enable <input type="radio"/> Disable
Audio Codec	G.711 μ -LAW <input type="button" value="v"/>
<input type="button" value="Apply"/>	

Primary Secondary Tertiary	
Camera Name	Primary Stream
Frame Rate	5 fps <input type="button" value="v"/>
Image Size	1920 x 1080 <input type="button" value="v"/>
Encoding Standard	M-JPEG <input type="button" value="v"/>
Image Quality	Normal <input type="button" value="v"/>
Audio	<input type="radio"/> Enable <input checked="" type="radio"/> Disable
<input type="button" value="Apply"/>	

Max. Video Encoding	2M x 30 fps <input type="button" value="v"/>
<input type="button" value="Apply"/>	

Figure 21. IZA500GR LPR Camera - Video & Device > Stream Setup (Video Streams)

10.8.2. IZA500GR LPR Camera - Video & Audio > Camera Setup

i NOTE

Click the Default(Day) link, and set the Shutter Time Max parameter according to the camera-to-plate distance (see next Figure):

Distance	Shutter Time Max
40 ft (12.2 m)	1/500
20 ft (6.0 m)	1/1000
15 ft (4.6 m)	1/2000
10 ft (3.0 m)	1/4000

i NOTE

Change the Exposure parameter "Environment" to Outdoor or Indoor, depending on your site's requirements.

Camera Settings

Default(Day) Night Mode DI Mode Motion Mode			
Event Control Mode			
Change Mode to	<input type="checkbox"/> Day	<input type="checkbox"/> Night	<input type="checkbox"/> DI
Exposure			
Environment	<input checked="" type="radio"/> Indoor <input type="radio"/> Outdoor		
AE Metering Mode	Average ▼		
Shutter Control	<input checked="" type="radio"/> Manual <input type="radio"/> Auto		
Shutter Time Min	1 / 4000	(30 ~ 32000)	
Shutter Time Max	1 / 4000	(30 ~ 32000)	
Max AGC gain	36	(Default:36, 0 ~ 72)	
Sense Up Level	Off ▼		
Back Light Compensation	<input type="radio"/> Enable <input checked="" type="radio"/> Disable		
Auto Exposure Weight	100	% (Default:100, 25 ~ 400)	
DOL WDR Enable	<input type="radio"/> Enable <input checked="" type="radio"/> Disable		
D-WDR	0	(Default:0, 0 ~ 128)	
Image Filter			
Brightness	0	(Default:0, -255 ~ 255)	
Contrast	64	(Default:64, 0 ~ 128)	
Hue	2	(Default:2, -15 ~ 15)	
Saturation	80	(Default:80, 0 ~ 255)	
Sharpness	6	(Default:6, 0 ~ 11)	
White Balance & Noise Filter			
White Balance	Auto ▼		
3DNR	3	(0 ~ 11)	
Day/Night & IR-LED Illumination			
Day & Night Control	Black & White ▼		
Day to Night Dwelling Time	3	(0 ~ 6)	
Night to Day Dwelling Time	3	(0 ~ 6)	
Day to night threshold	2000	(1 ~ 4096)	
Night to day threshold	3500	(1 ~ 4096)	
Image Direction			
Vertical Flip	<input type="radio"/> Enable <input checked="" type="radio"/> Disable		
Horizontal Flip	<input type="radio"/> Enable <input checked="" type="radio"/> Disable		
Corridor Mode	<input type="radio"/> Enable <input checked="" type="radio"/> Disable		

Color Mode : Default	Color Mode : Standard
Color Mode : Vivid	Copy Default to All

Apply

Figure 22. IZA500GR LPR Camera - Video & Audio > Camera Setup

10.8.3. IZA500GR LPR Camera - System > Access Level

Access Level

Access Permission

<input checked="" type="radio"/> Full Access (View and control camera & audio without permission)
<input type="radio"/> Limited Access (In accordance with an user's permission)
<input type="button" value="Apply"/>

Authentication

<input checked="" type="radio"/> Unencrypted only <input type="radio"/> Encrypted only <input type="radio"/> Encrypted & Unencrypted
<input type="button" value="Apply"/>

Notice : In order to apply the settings to the 'Access Control Configuration', reconnection is required after closing the browser.

Figure 23. IZA500GR LPR Camera - System > Access Level

10.9. IZA500GR OV Camera (Sensor) Configuration

The camera(s) are usually pre-configured; this section displays typical settings for reference.

! IMPORTANT

Settings shown are for a typical site; they may be different depending on you site's requirements and camera firmware versions.

After changing settings, remember to click the Apply button at the bottom of each parameter section.

10.9.1. IZA500GR OV Camera - Video & Audio > Stream Setup (Video Streams)

Stream Setup

Max Frame Rate	<input checked="" type="radio"/> 30 fps <input type="radio"/> 25 fps
Video with Flexible Extra System data	<input type="checkbox"/> Enable
Video with user defined message	<input type="checkbox"/> Enable
Video with PPP status	<input type="checkbox"/> Enable
Video with camera name	<input type="checkbox"/> Enable
Video with server name	<input type="checkbox"/> Enable
Video with IP address	<input type="checkbox"/> Enable
Time Stamp	Off <input type="button" value="v"/>
TV Out	<input checked="" type="radio"/> Enable <input type="radio"/> Disable
Audio Codec	G.711 μ -LAW <input type="button" value="v"/>
<input type="button" value="Apply"/>	

Primary Secondary Tertiary	
Camera Name	Primary Stream
Frame Rate	5 fps <input type="button" value="v"/>
Image Size	1920 x 1080 <input type="button" value="v"/>
Encoding Standard	M-JPEG <input type="button" value="v"/>
Image Quality	Normal <input type="button" value="v"/>
Audio	<input type="radio"/> Enable <input checked="" type="radio"/> Disable
<input type="button" value="Apply"/>	

Max. Video Encoding	2M x 30 fps <input type="button" value="v"/>
<input type="button" value="Apply"/>	

Figure 24. IZA500GR OV Camera - Video & Audio > Stream Setup (Video Streams)

10.9.2. IZA500GR OV Camera - Video & Audio > Camera Setup

i NOTE

Click the Default(Day) link, and set the Shutter Time Max parameter according to the camera-to-plate distance (see next Figure):

Distance	Shutter Time Max
40 ft (12.2 m)	1/500
20 ft (6.0 m)	1/1000
15 ft (4.6 m)	1/2000
10 ft (3.0 m)	1/4000

i NOTE

Change the Exposure parameter "Environment" to Outdoor or Indoor, depending on your site's requirements.

Camera Settings

Default(Day) Night Mode DI Mode Motion Mode			
Event Control Mode			
Change Mode to	Day <input type="checkbox"/>	Night <input type="checkbox"/>	DI <input type="checkbox"/>
Exposure			
Environment	<input checked="" type="radio"/> Indoor <input type="radio"/> Outdoor		
AE Metering Mode	Average ▼		
Shutter Control	<input checked="" type="radio"/> Manual <input type="radio"/> Auto		
Shutter Time Min	1 / 32000	(30 ~ 32000)	
Shutter Time Max	1 / 2500	(30 ~ 32000)	
Max AGC gain	36	(Default:36, 0 ~ 72)	
Sense Up Level	Off ▼		
Back Light Compensation	<input type="radio"/> Enable <input checked="" type="radio"/> Disable		
Auto Exposure Weight	100	% (Default:100, 25 ~ 400)	
DOL WDR Enable	<input type="radio"/> Enable <input checked="" type="radio"/> Disable		
D-WDR	0	(Default:0, 0 ~ 128)	
Image Filter			
Brightness	0	(Default:0, -255 ~ 255)	
Contrast	64	(Default:64, 0 ~ 128)	
Hue	2	(Default:2, -15 ~ 15)	
Saturation	80	(Default:80, 0 ~ 255)	
Sharpness	6	(Default:6, 0 ~ 11)	
White Balance & Noise Filter			
White Balance	Auto ▼		
3DNR	3	(0 ~ 11)	
Day/Night & IR-LED Illumination			
Day & Night Control	Color ▼		
Day to Night Dwelling Time	3	(0 ~ 6)	
Night to Day Dwelling Time	3	(0 ~ 6)	
Day to night threshold	2000	(1 ~ 4096)	
Night to day threshold	3500	(1 ~ 4096)	
Image Direction			
Vertical Flip	<input type="radio"/> Enable <input checked="" type="radio"/> Disable		
Horizontal Flip	<input type="radio"/> Enable <input checked="" type="radio"/> Disable		
Corridor Mode	<input type="radio"/> Enable <input checked="" type="radio"/> Disable		

Color Mode : Default	Color Mode : Standard
Color Mode : Vivid	Copy Default to All

Apply

Figure 25. IZA500GR OV Camera - Video & Audio > Camera Setup

10.9.3. IZA500GR OV Camera - System > Access Level

Access Level

Access Permission

<input checked="" type="radio"/> Full Access (View and control camera & audio without permission)
<input type="radio"/> Limited Access (In accordance with an user's permission)
<input type="button" value="Apply"/>

Authentication

<input checked="" type="radio"/> Unencrypted only <input type="radio"/> Encrypted only <input type="radio"/> Encrypted & Unencrypted
<input type="button" value="Apply"/>

Notice : In order to apply the settings to the 'Access Control Configuration', reconnection is required after closing the browser.

Figure 26. IZA500GR OV Camera - System > Access Level

11. Aim and Calibrate

There are two cameras in the Camera System. Both are calibrated in nearly the same way. The LPR camera is typically set to capture in black and white, and the Overview (OV) camera is typically set to capture in color.

The OV camera can be used both to display an overview image, and to perform LPR recognition. You may even be able to improve read accuracy by changing the zoom to have one camera "see" closer than the other one.

11.1. Preparing a Vehicle/License Plate

Move a vehicle next to, and at the middle of the capture line. (This is the position at which the vehicle sensor signals that the vehicle is present.) Ensure that the Camera System is aimed at the middle of the lane, and is at the required capture distance (see Section 5 and the IZA500G-F5/GR-F5 User Guide - see Section 1).

Alternatively, in a lab, position a license plate at the expected distance and height.

11.2. Determining the IP Address of the RoadView Computer with IZ Discovery

See the IZ Discovery User Guide (see Section 1).

11.3. Using RoadView

11.3.1. Logging In

1. Open a browser (Chrome or Microsoft Edge). Type in the IP address of the RoadView computer.

For example:

192.168.5.110

2. You will see the login screen. Enter the default username and password (root, root):

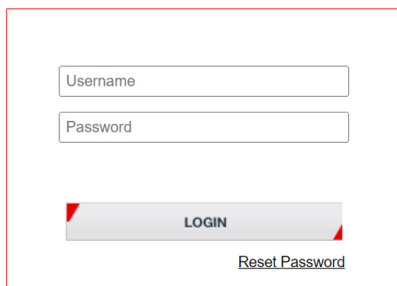

Figure 27. Logging In to RoadView

3. You should see the RoadView Live (Journal) tab. See the RoadView ALPR User Guide for instructions for configuring and using RoadView (see Section 1).

11.3.2. Logging Out

See the RoadView ALPR User Guide (see Section 1) for logout instructions, using the multi-line drop-down menu icon in the upper right corner of the screen.

11.4. Calibrating the Cameras Using RoadView

See the RoadView ALPR User Guide (see Section 1) for calibration instructions.

12. Verify System Operation

- Using a license plate mounted in a lab, or by driving a vehicle through the lane, verify that an Event is generated with the correct plate read (recorded in the RoadView Live (Journal) tab - see the RoadView ALPR User Guide). See Section 1.
- Once the lane is active, verify that Events are being generated for each vehicle passing each camera, and that the recognition has sufficient accuracy and confidence.

13. Troubleshooting and Maintenance

13.1. Troubleshooting

See the RoadView ALPR User Guide (see Section 1).

13.2. Checking Mounting Screws

It is recommended to check all mounting screws for proper tightness once every two years.

13.3. Cleaning the ALPR Camera System

Do not use solvents or strong abrasive detergent when cleaning the Camera System. Use a soft dry cloth to clean the ALPR Camera System's front glass when it is dirty. If the dirt has hardened, remove it using mild soap and water, and then wipe the front window gently.

14. Notices

14.1. Inex Technologies End User Agreement

Be sure to read the following document that explains important information about your agreement with Inex. [Inex Technologies End User Agreement](#)

14.2. Safety Precautions

⚠ CAUTION

WHEN INSTALLING THE UNIT IN YOUR SYSTEM, BEWARE OF RISK OF ELECTRICAL SHOCK.
REFER SERVICING TO QUALIFIED SERVICE PERSONNEL

! IMPORTANT

This product must be used in compliance with local laws and regulations.
All network cable extensions and repeaters must be shielded.
Power undervoltage, overvoltage and/or incorrect polarity will damage the unit and will void the warranty.

- Read this guide carefully before installation, and keep it for future reference.
- Do not disassemble the ALPR Camera System or external illuminator units. Repair or replacement of parts for this ALPR Camera System and its external illuminator units should be supplied by Inex Technologies, and installed by qualified service personnel.
- Handle and store the ALPR Camera System and external illuminator units with care.
- You must provide adequate protection to prevent water (e.g. rain) from entering the ALPR Camera System.
- Do not use the ALPR Camera System or external illuminator units outside of their temperature, humidity and power source ratings as noted in their respective technical specifications.
- To avoid heat accumulation/overheating, use sufficient ventilation in the unit's operating environment.
- It is your responsibility to ensure that all wires connected to Inex Technologies' products have appropriate surge protection. Any damage due to electrical spikes (for example, lightning) is not covered by the warranty.
- Do not connect several devices to one power adapter since adapter overload may cause overheating or a fire hazard.
- Stop using the unit immediately if it emits smoke, or if you notice an abnormal smell or sound. In such cases, please contact us. Do not attempt to repair the unit by yourself!

- **Eye Safety: The following precautions must be observed:**
 - Do not stare directly into the front of the ALPR Camera System while it is operating.
 - IZA500G-F5/GR-F5 - IEC62471 Group 1:





14.3. Regulatory Notices

-  **FCC Conformance:**

This device complies with Part 15 of the FCC Rules. Operation is subject to the following two conditions: (1) This device may not cause harmful interference, and (2) this device must accept any interference received, including interference that may cause undesired operation.
-  **EU Conformity Statement:**

This product and - if applicable, the supplied accessories - are marked with "CE" and comply therefore with the applicable harmonized European standards listed under the EMC Directive 2014/30/EU, and the RoHS Directive 2002/95/EC.
-  **IP67 Ingress Protection:**

This product conforms to the IP67 standard.
-  **IK10:**

This device's casting/housing conforms to the IK10 impact standard (Vandal-proof).
-  **ONVIF:**

This device is ONVIF compliant (Profile S).

14.4. Documentation Notices

Inex Technologies reserves the right to improve and enhance its product offerings. Thus, the illustrations and descriptions presented in this manual may differ in some respect from the products you receive.

Technical specifications are subject to change without notice.

In addition, please note that some figures are not drawn to scale, in order to illustrate the addressed issue more effectively.

All third-party trademarks are the property of their respective owners.

Inex Technologies cannot be held liable for technical and editorial omissions or errors made in this document; nor for incidental or consequential damages resulting from the furnishing, performance or use of this document.

No part of this document may be reproduced in any form without permission from Inex Technologies.

15. Document Change History

Date	Change
2023-07-24	<ul style="list-style-type: none"> • Removed references to Video Analytics Data Sheet from Related Documents and spec. tables; made reference to RoadView documentation generic • Added IZ Discovery User Guide to Related Documents; removed IZ Discovery sections and referred user to Related Documents
2024-10-29	<p>IZA500G:</p> <ul style="list-style-type: none"> • Input voltage now only 24VDC only (without additional 48VDC as previously) • Power input option of PoE+ (P48 models) removed • Model number deletions to accommodate changed power options <p>IZA500GR:</p> <ul style="list-style-type: none"> • Power input option of 48VDC/PoE+ (P48 models) removed; P24 models remain • Model number deletions to accommodate changed power options
2023-12-18	<ul style="list-style-type: none"> • New camera sensor configuration screen shots and associated notes
2024-12-22	<ul style="list-style-type: none"> • Updated sensor screen shots to match a typical site • Added table of guidelines for Shutter Time Max parameter
2025-07-08	<ul style="list-style-type: none"> • Replaced new version (2.2) of IZxPOE in wiring diagrams • Update to IZA500GR Rev. F4: Added text throughout explaining that the IZA500GR can now connect directly to a standard PoE++ switch • Update to IZA500GR Rev. F4: Added PoE++ IEEE 802.3bt (Type 3, Class 6) to PoE types supported • Update to IZA500GR Rev. F4: Power consumption now 30 W instead of 25 W
2025-09-01	<ul style="list-style-type: none"> • Added text and changed filename to highlight revision differences between IZA500G (Rev. F3) and IZA500GR (Rev. F4)

Date	Change
2025-09-25	<ul style="list-style-type: none"> • Removed IZL from Accessories in the specification table, from Related Documents and from Optional Accessories in text • Removed several mentions of illuminators in the text • Removed "Optimizing Nighttime Vehicle Overview Images (using External Illuminators)" section
2025-12-10	<p>Updates to IZA500G Rev. F5:</p> <ul style="list-style-type: none"> • Changed System Storage specification to SSD, 64 GB • Changed Data Storage specification to SSD, 64 GB minimum guaranteed • Added Operating System specification: "NVIDIA Jetson Linux (L4T), JetPack 4.6.6" <p>Updates to IZA500GR Rev. F5:</p> <ul style="list-style-type: none"> • Changed System Storage specification to SSD, 64 GB • Changed Data Storage specification to SSD, 64 GB minimum guaranteed • Added Operating System specification: "NVIDIA Jetson Linux (L4T), JetPack 4.6.6"
2026-01-04	<ul style="list-style-type: none"> • IZA500GR: Removed texts mentioning requirement for Inex PoE++ injectors only
2026-03-19	<ul style="list-style-type: none"> • Corrected LPR Capture Distance description in a Figure to clarify that this distance is measured from camera-to-plate "along the road"

© Inex Technologies, LLC - All rights reserved.

Doc. No. IZA500G-F5-GR-F5-MAN-002b Ver. 2026-04-12

This page was built using the Antora default UI.

The source code for this UI is licensed under the terms of the MPL-2.0 license.